



## المنظمة العربية للتنمية الصناعية والتعدين

مركز المواصفات والمقاييس

### مشروع مواصفة قياسية عربية

بلاط السيراميك - الملاط والمواد اللاصقة الجزء ٢ : طرق اختبار المواد  
اللاصقة للبلاط

### **Ceramic tiles -- Grouts and adhesives -- Part 2: Test methods for adhesives**

#### إعداد: الهيئة العامة للصناعة-دولة الكويت

هذه الوثيقة مشروع مواصفة قياسية عربية تم عرضها على القاعدة التفاعلية لإبداء الرأي والملاحظات عليها، لذلك فإنها عرضة للتغيير والتبديل ولا يجوز الاعتماد عليها كمواصفة قياسية عربية موحدة إلا بعد اعتمادها من قبل اللجنة الاستشارية العليا للتقييس والمجلس التنفيذي

للمنظمة العربية للتنمية الصناعية والتعدين

---

---

**Ceramic tiles — Grouts and adhesives —  
Part 2:  
Test methods for adhesives**

*Carreaux céramiques — Mortiers de joints et colles —  
Partie 2: Méthodes d'essai pour les colles*



**PDF disclaimer**

This PDF file may contain embedded typefaces. In accordance with Adobe's licensing policy, this file may be printed or viewed but shall not be edited unless the typefaces which are embedded are licensed to and installed on the computer performing the editing. In downloading this file, parties accept therein the responsibility of not infringing Adobe's licensing policy. The ISO Central Secretariat accepts no liability in this area.

Adobe is a trademark of Adobe Systems Incorporated.

Details of the software products used to create this PDF file can be found in the General Info relative to the file; the PDF-creation parameters were optimized for printing. Every care has been taken to ensure that the file is suitable for use by ISO member bodies. In the unlikely event that a problem relating to it is found, please inform the Central Secretariat at the address given below.



**COPYRIGHT PROTECTED DOCUMENT**

© ISO 2010

All rights reserved. Unless otherwise specified, no part of this publication may be reproduced or utilized in any form or by any means, electronic or mechanical, including photocopying and microfilm, without permission in writing from either ISO at the address below or ISO's member body in the country of the requester.

ISO copyright office  
Case postale 56 • CH-1211 Geneva 20  
Tel. + 41 22 749 01 11  
Fax + 41 22 749 09 47  
E-mail [copyright@iso.org](mailto:copyright@iso.org)  
Web [www.iso.org](http://www.iso.org)

Published in Switzerland

# Contents

Page

Foreword .....	iv
<b>1 Scope .....</b>	<b>1</b>
<b>2 Normative references .....</b>	<b>1</b>
<b>3 General test conditions and procedures .....</b>	<b>1</b>
3.1 Sampling.....	1
3.2 Test conditions .....	1
3.3 Test materials .....	2
3.4 Mixing procedures.....	2
3.5 Test substrate .....	3
3.6 Failure patterns.....	3
3.7 Test report.....	3
<b>4 Test methods .....</b>	<b>4</b>
4.1 Determination of open time .....	4
4.2 Determination of slip.....	6
4.3 Determination of shear adhesion strength — D, R .....	7
4.4 Determination of tensile adhesion strength — C .....	9
4.5 Determination of transverse deformation.....	12
4.6 Determination of chemical resistance.....	13
<b>Annex A (informative) Concrete test slab.....</b>	<b>32</b>

## Foreword

ISO (the International Organization for Standardization) is a worldwide federation of national standards bodies (ISO member bodies). The work of preparing International Standards is normally carried out through ISO technical committees. Each member body interested in a subject for which a technical committee has been established has the right to be represented on that committee. International organizations, governmental and non-governmental, in liaison with ISO, also take part in the work. ISO collaborates closely with the International Electrotechnical Commission (IEC) on all matters of electrotechnical standardization.

International Standards are drafted in accordance with the rules given in the ISO/IEC Directives, Part 2.

The main task of technical committees is to prepare International Standards. Draft International Standards adopted by the technical committees are circulated to the member bodies for voting. Publication as an International Standard requires approval by at least 75 % of the member bodies casting a vote.

Attention is drawn to the possibility that some of the elements of this document may be the subject of patent rights. ISO shall not be held responsible for identifying any or all such patent rights.

ISO 13007-2 was prepared by Technical Committee ISO/TC 189, *Ceramic tiles*.

This second edition cancels and replaces the first edition (ISO 13007-2:2005), which has been technically revised. It also incorporates the Technical Corrigendum ISO 13007-2:2005/Cor.1:2007.

ISO 13007 consists of the following parts, under the general title *Ceramic tiles — Grouts and adhesives*:

- *Part 1: Terms, definitions and specifications for adhesives*
- *Part 2: Test methods for adhesives*
- *Part 3: Terms, definitions and specifications for grouts*
- *Part 4: Test methods for grouts*

# Ceramic tiles — Grouts and adhesives —

## Part 2: Test methods for adhesives

### 1 Scope

This part of ISO 13007 describes methods for determining characteristics for adhesives used in the installation of ceramic tiles. The test methods described are the following:

- a) determination of open time;
- b) determination of slip;
- c) determination of shear adhesion strength;
- d) determination of tensile adhesion strength;
- e) determination of transverse deformation;
- f) determination of chemical resistance.

### 2 Normative references

The following referenced documents are indispensable for the application of this part of ISO 13007. For dated references, only the edition cited applies. For undated references, the latest edition of the referenced document (including any amendments) applies.

ISO 13006, *Ceramic tiles — Definitions, classification, characteristics and marking*

ISO 13007-1, *Ceramic tiles — Grouts and adhesives — Part 1: Terms, definitions and specifications for adhesives*

### 3 General test conditions and procedures

#### 3.1 Sampling

A representative sample of at least 2 kg shall be used.

#### 3.2 Test conditions

Standard test conditions shall be  $(23 \pm 2)$  °C and  $(50 \pm 5)$  % relative humidity and the speed of air in the testing area less than 0,2 m/s. Other test conditions may be specified in Clause 4. The tolerance in the time of conditioning for all test specimens shall be as shown in Table 1.

Table 1 — Allowable tolerance window for testing time

Sample conditioning time <sup>a</sup>	Allowed tolerance for testing <sup>b</sup>
24 h	±0,5 h
7 days	±3 h
14 days	±6 h
21 days	±9 h
28 days	±12 h
<sup>a</sup> Testing shall be performed within the specified time window.	
<sup>b</sup> Allowed tolerance in testing time for all samples requiring conditioning.	

### 3.3 Test materials

Condition all test materials, including water for at least 24 h under standard conditions. The adhesive under test shall be within its shelf life, if this is specified.

#### 3.3.1 Ceramic tiles

The tiles shall be checked prior to conditioning to ensure that they are unused, clean and dry. The type of tile shall be as specified under the specific test procedures given in Clause 4.

### 3.4 Mixing procedures

#### 3.4.1 Cementitious adhesives — C

The amount of water and liquid admix, or one or the other, required for preparing the adhesive shall be as stated by the manufacturer in mass fraction, i.e. liquid to dry powder (in the case where a range of values is given, the average shall be used).

Using a minimum quantity of 2 kg of the powder and the recommended quantity of liquid, prepare the adhesive in a mixer of the planetary type using the slow speed settings (140 ± 5) r/min and (62 ± 5) r/min planetary movement (see Figures 1 and 2).

Carry out the following procedure:

- a) pour the liquid into the pan;
- b) scatter the dry powder over the liquid;
- c) mix for 30 s;
- d) take out the mixing paddle;
- e) scrape down the paddle and pan within 1 min;
- f) replace the paddle and mix for 1 min.

If required by the adhesive manufacturer's instructions, let the adhesive mature as specified and then mix for an additional 15 s.

### 3.4.2 Dispersion adhesive — D, Reaction resin adhesive — R

If ready-to-use dispersion adhesives or reaction resin adhesives are used, the manufacturer's instructions shall be followed.

## 3.5 Test substrate

### 3.5.1 Concrete test substrate

The mandatory concrete test substrate shall be  $(40 \pm 5)$  mm thick, have a moisture content of less than 3 % mass fraction and have a water absorption at the surface after 4 h of testing in range of  $0,5 \text{ cm}^3$  to  $1,5 \text{ cm}^3$ . The cohesive strength, as referenced in A.4.3, shall be at least  $1,5 \text{ N/mm}^2$ . A method of manufacturing a suitable concrete test slab and the procedures for measuring the cohesive strength and surface water absorption is given in Annex A.

### 3.5.2 Other substrates

Other substrates may be used upon agreement, if the substrate is recommended for ceramic tile application by the adhesive manufacturer. To demonstrate compatibility with other optional substrates, the adhesive shall be applied to the selected substrate in accordance with the open time test method (4.1). When the result of  $\geq 0,5 \text{ N/mm}^2$  is achieved or cohesive failure occurs in the substrate, the requirement is considered satisfied.

## 3.6 Failure patterns

### 3.6.1 Adhesion failure — AF-S or AF-T

Failure occurs at the interface between adhesive and substrate (AF-S) or between tile and adhesive (AF-T). The test value equals the adhesive strength [see Figure 3 a) and b)]. In some cases, failure can occur in the adhesive layer between the tile and the pull-head plate (BF) [see Figure 3 c)]. In this case, the adhesive strength is greater than the test value, and the test should be repeated.

### 3.6.2 Cohesive failure within the adhesive — CF-A

Failure occurs within the adhesive layer [see Figure 3 d)].

### 3.6.3 Cohesive failure in the substrate or in the tile — CF-S or CF-T

The failure occurs within the substrate (CF-S) [see Figure 3 e)] or within the body of the tile (CF-T) [see Figure 3 f)]. In this case, the strength of the adhesive is greater than the test value.

The modes of failure may be a combination of any of the above. An approximate percentage of each shall be recorded.

## 3.7 Test report

### 3.7.1 General

The test report shall specify the following:

- a) reference to this part of ISO 13007, i.e. ISO 13007-2:2010;
- b) date of test;
- c) type of adhesive, commercial designation and manufacturer's name;
- d) source, date obtained and complete identification of test sample;



- e) handling and storage of samples before testing;
- f) test conditions;
- g) amount of water or liquid used for preparing adhesive;
- h) any other factor that could have affected the result;
- i) test results (individual and mean values and mode of failure, if required).

### **3.7.2 Test results of cementitious and dispersion adhesives**

The test report shall specify the following:

- a) open time;
- b) slip;
- c) shear adhesion strength;
- d) adhesion strength;
- e) deformation.

### **3.7.3 Test results of chemical resistance**

The test report shall specify the following:

- a) test conditions;
- b) change in colour and surface appearance during the test;
- c) total duration of the test and the exposure periods.

## **4 Test methods**

### **4.1 Determination of open time**

#### **4.1.1 General**

Open time shall be tested following the general test conditions and procedures given in Clause 3 and the following specific instructions.

#### **4.1.2 Test materials**

**4.1.2.1 Ceramic tiles**, Group BIII, belonging to porous body tile, complying with ISO 13006 of water absorption ( $15 \pm 3$ ) % mass fraction, cut to facial dimensions of  $(50 \pm 1)$  mm  $\times$   $(50 \pm 1)$  mm, with a thickness in the range of 7 mm to 10 mm and a profile back pattern less than 0,25 mm deep.

**4.1.2.2 Test substrate**, made of concrete, conforming to the requirements given in 3.5.1.

#### **4.1.3 Apparatus**

**4.1.3.1 Test mass**, of less than 50 mm  $\times$  50 mm cross-sectional area, capable of exerting a uniform force of  $(20 \pm 0,05)$  N.

**4.1.3.2 Pull-head plates**, consisting of square metallic plates, with dimensions of  $(50 \pm 1)$  mm and a minimum thickness of 10 mm with a suitable fitting for connection to the test machine.

**4.1.3.3 Test machine**, for direct pull tensile force test and with suitable capacity and sensitivity for the test. The machine shall be capable of applying the load to the pull-head plate at the rate of  $(250 \pm 50)$  N/s through a suitable fitting that does not exert any bending force.

#### 4.1.4 Procedure

Apply a thin layer of the adhesive, mixed in accordance with 3.4.1, to the concrete slab with a straight edge trowel. Then apply a thicker layer and comb with a notched trowel having  $6 \text{ mm} \times 6 \text{ mm}$  notches at 12 mm centres. The trowel shall be held at an angle of approximately  $60^\circ$  to the substrate at a right angle to one edge of the slab and drawn across the slab parallel to that edge (in a straight line).

After 5 min, 10 min, 20 min, 30 min or more, place at least 10 test tiles 50 mm apart, on the adhesive within 30 s: place tiles on no more than 4 ribs for all adhesives. Load each tile with  $(20 \pm 0,05)$  N for 30 s.

After 27 days of storage under standard conditions, bond the pull-head plates to the tiles with a suitable high strength adhesive (e.g. epoxy adhesive).

After a further 24 h storage under standard conditions, determine the tensile adhesion strength of the adhesive by applying a force increasing at a constant rate of  $(250 \pm 50)$  N/s.

#### 4.1.5 Evaluation and expression of results

The individual tensile adhesion strengths are quoted to  $0,1 \text{ N/mm}^2$  using Equation (1):

$$S_a = \frac{F}{A} \quad (1)$$

where

$S_a$  is the individual tensile adhesion strength, in newtons per square millimetre;

$F$  is the total tensile load, in newtons;

$A$  is the bonding area, in square millimetres ( $2\,500 \text{ mm}^2$ ).

The tensile adhesion strength for each time interval is determined as follows:

- a) determine the mean of the 10 values;
- b) discard the values falling out of the range of  $\pm 20\%$  of the mean value;
- c) if five or more values remain, determine the new mean;
- d) if less than five values remain, repeat the test;
- e) determine the mode of failure of the test units (see 3.6).

The open time, in minutes, is the maximum time interval at which the adhesive meets the tensile adhesion strength requirement defined in ISO 13007-1 for open time.

#### 4.1.6 Test report

The information listed in 3.7.1, list items a) to i), shall be provided plus 3.7.2, list item a) (open time in minutes).

## 4.2 Determination of slip

### 4.2.1 General

Slip shall be tested following the general test conditions and procedures given in Clause 3 and the following specific instructions.

### 4.2.2 Test materials

**4.2.2.1 Ceramic tiles**, belonging to Group BI<sub>a</sub>, fully vitrified in accordance with ISO 13006 with a water absorption  $\leq 0,5$  % mass fraction, unglazed, with plain adhering surface and with facial dimensions of  $(100 \pm 1)$  mm  $\times$   $(100 \pm 1)$  mm and mass of  $(200 \pm 10)$  g and a thickness in the range of 8 mm to 10 mm.

**4.2.2.2 Concrete test substrate**, conforming to requirements given in 3.5.

### 4.2.3 Apparatus

**4.2.3.1 Steel straight edge.**

**4.2.3.2 Clamps.**

**4.2.3.3 Masking tape**, 25 mm wide.

**4.2.3.4 Spacers**, two  $(25 \pm 0,5)$  mm  $\times$   $(25 \pm 0,5)$  mm  $\times$   $(10 \pm 0,5)$  mm thick spacers made from stainless steel.

**4.2.3.5 Mass**, capable of exerting a force of  $(50 \pm 0,1)$  N with a cross-sectional area of less than  $(100 \pm 1)$  mm  $\times$   $(100 \pm 1)$  mm.

**4.2.3.6 Vernier calliper**, accurate to 0,01 mm.

### 4.2.4 Procedure

Secure the steel straight edge at the top of the concrete substrate such that its bottom edge is horizontal when the slab is raised to its vertical position. Position 25 mm-wide masking tape immediately below the steel straight edge and apply a thin layer of the adhesive to the concrete slab with a straight-edge trowel.

Apply a thicker layer of adhesive to the surface of the concrete substrate such that it just overlaps the bottom edge of the masking tape. Comb the adhesive at right angles to the straight edge with a notched trowel having 6 mm  $\times$  6 mm notches at 12 mm centres.

Hold trowel at an angle of 60° to the substrate and parallel to the straight edge.

Immediately remove the masking tape, position 25 mm spacers (or the spacing bar) as shown against the straight edge and after 2 min place a type BI<sub>a</sub> tile against the spacers, as shown in Figure 4, and load with a mass of  $(50 \pm 0,1)$  N for  $(30 \pm 5)$  s.

Remove the spacers and measure the gap between the straight edge and the tile with the Vernier caliper to within  $\pm 0,1$  mm. Immediately and carefully lift the slab into a vertical position. After  $(20 \pm 2)$  min re-measure the gap, as before, at its maximum point. The maximum slip of the tile under its own mass is the difference between the two readings.

Carry out the test for each of three tiles, for each adhesive. Report the results in millimetres and the mean value.

#### 4.2.5 Test report

The information listed in 3.7.1, list items a) to i), shall be provided plus 3.7.2, list item b): slip in mm (individual and mean values).

### 4.3 Determination of shear adhesion strength — D, R

#### 4.3.1 General

Shear adhesion strength shall be tested following the general test conditions and procedures given in Clause 3 and the following specific instructions.

#### 4.3.2 Test materials and apparatus

##### 4.3.2.1 Ceramic tiles, of the following specification.

- a) Dispersion adhesives (D) — Group BIII, glazed porous body tiles in accordance with ISO 13006; with water absorption  $(15 \pm 3)$  % mass fraction, with facial dimensions of  $(108 \pm 1)$  mm  $\times$   $(108 \pm 1)$  mm and a thickness in the range of 7 mm to 10 mm and a profile back pattern less than 0,25 mm thick.
- b) Reaction resin adhesives (R) — Group BI<sub>a</sub>, fully vitrified tiles in accordance with ISO 13006; with water absorption  $\leq 0,2$  % mass fraction, unglazed with plane adhering surface and with facial dimensions of  $(100 \pm 1)$  mm  $\times$   $(100 \pm 1)$  mm.

**4.3.2.2 Template**, comprising a smooth non-absorbent frame (e.g. polytetrafluoroethylene), in accordance with Figure 5 for D adhesives and Figure 7 for R adhesives.

**4.3.2.3 Spacers**, of 0,8 mm in diameter, and approximately 40 mm long.

**4.3.2.4 Mass**, of less than 100 mm  $\times$  100 mm cross-sectional area, capable of exerting a uniform force of  $(70 \pm 0,15)$  N.

**4.3.2.5 Test machine**, with suitable capacity and sensitivity for the test and with a variable testing speed. The machine shall be capable of applying the load to the tile through a suitable jig.

**4.3.2.6 Shear test jig**, suitable for use to transfer into shear from the compression or tensile load exerted by the testing machine. Examples of suitable jigs are shown in Figures 9 and 10.

**4.3.2.7 Air circulating oven**, capable of controlling the temperature to within  $\pm 3$  °C.

#### 4.3.3 Procedure

Each test unit shall be prepared with two Group BIII tiles for D adhesives or Group BI<sub>a</sub> tiles for R adhesives.

Draw a straight line on the adhering side of one tile 6 mm from the tile edge (to serve as a guide for overlapping the tile as explained as follows).

Place the template (see Figures 5 and 7) over the unglazed back of the first test tile. Trowel sufficient adhesive across the template and then screed it clean such as to neatly and completely fill the holes in the template. Carefully remove the template vertically (see Figures 6 and 8).

Place spacer rods at each corner of the first tile, approximately 20 mm over the tile. After 2 min, place a second standard test tile over the coated tile, offset to provide an overlap between tiles with displacement of 6 mm, using the previously scribed line as a guide and ensuring that the edges of the tiles are parallel (see Figure 6 for D adhesives and Figure 8 for R adhesives).

Place the test units on a plane surface and carefully load with  $(70 \pm 0,15)$  N for 3 min. After removing the mass, carefully remove the spacer rods, without disturbing the relative position of the tiles in the test units. A total of 10 test units is required per conditioning.

#### **4.3.4 Adhesion strength — D, R**

**4.3.1.1** Condition 10 test units in standard test conditions (see 3.2); 7 days for R adhesives or 14 days for D adhesives.

**4.3.1.2** After conditioning has been completed, place the test units in a shear test jig and apply a shear force by moving the crosshead at a speed of  $(5 \pm 0,5)$  mm/min until failure occurs. Report the results in newtons.

#### **4.3.5 Adhesion strength after water immersion — D, R**

Condition 10 test units in standard conditions (see 3.2) for 21 days for adhesives (D2) or 7 days for accelerated drying adhesives (D2A) and reaction resin adhesives (R). Then immerse in water at  $(23 \pm 2)$  °C 21 days for reaction resin adhesives or 7 days for dispersion adhesives (D2; D2A). Remove the units and wipe with a cloth. Test them as described in 4.4.4.2.

Report the results in newtons.

NOTE This test is only for those dispersion adhesives used in internal installations subject to wet conditions.

#### **4.3.6 Adhesion strength after heat ageing — D**

Condition 10 test units in standard conditions (see 3.2) for 14 days and then place them in an air-circulating oven at  $(70 \pm 2)$  °C for a further 14 days, ensuring that air is free to circulate around each test unit.

Condition the units for a further 24 h in standard conditions and test them as described in 4.3.4.

Report the results in newtons.

#### **4.3.7 Adhesion strength at elevated temperature — D**

Use the procedure described in 4.3.6, but test the tile adhesion 1 min after removal of test unit from air circulating oven.

Report the results in newtons.

#### **4.3.8 Adhesion strength after thermal shock — R**

After conditioning 10 test units in standard conditions for 7 days, place the test pieces in a water bath maintained at  $(23 \pm 2)$  °C for 30 min and then in a  $(100 \pm 2)$  °C water bath for a further 30 min.

Repeat the cycle for a total of four times and then place the test pieces in the  $(23 \pm 2)$  °C bath for approximately 30 min for cooling.

Remove each test piece from the water, wipe off the excess water and test as described in 4.3.4.

Report the results in newtons.

#### 4.3.9 Evaluation and expression of results

Divide the individual values, in newtons, by the area of adhesive contact (D: 5480 mm<sup>2</sup>, R: 1660 mm<sup>2</sup>).

Determine the shear adhesion strength in the following way:

- a) determine the mean of 10 values;
- b) discard the values falling out of the range of  $\pm 20\%$  from the mean value;
- c) if five or more values remain, determine the new mean value;
- d) if less than five values remain, repeat the test.

#### 4.3.10 Test report

The information listed in 3.7.1, list items a) to i), shall be provided plus 3.7.2 list item c): shear adhesion strength for each condition, in newtons per square millimetre.

### 4.4 Determination of tensile adhesion strength — C

#### 4.4.1 General

Tensile adhesion strength shall be tested following the general test conditions and procedures given in Clause 3 and the following specific instructions.

#### 4.4.2 Test materials

**4.4.2.1 Ceramic tiles**, belonging to Group BI<sub>a</sub>, fully vitrified, complying with ISO 13006, with a water absorption of  $\leq 0,5\%$  mass fraction, unglazed and with a plain, matt, adhering surface, with facial dimensions of  $(50 \pm 1) \text{ mm} \times (50 \pm 1) \text{ mm}$ .

**4.4.2.2 Test substrate**, conforming to requirements given in 3.5.

#### 4.4.3 Apparatus

**4.4.3.1 Mass**, less than  $50 \text{ mm} \times 50 \text{ mm}$  cross-sectional area, capable of exerting a force of  $(20 \pm 0,05) \text{ N}$ .

**4.4.3.2 Pull-head plate**, consisting of square metallic plates, with dimensions of  $(50 \pm 1) \text{ mm} \times (50 \pm 1) \text{ mm}$  and a minimum thickness of 10 mm with a suitable fitting for connection to the test machine.

**4.4.3.3 Tensile testing apparatus**, consisting of a test machine for direct pull tensile force test, with suitable capacity and sensitivity for the test. The machine shall be capable of applying the load to the pull-head plate at the rate of  $(250 \pm 50) \text{ N/s}$  through a suitable fitting that does not exert any bending force.

**4.4.3.4 Air circulating oven**, capable of controlling the temperature to within  $\pm 3 \text{ }^\circ\text{C}$ .

#### 4.4.4 Procedure

##### 4.4.4.1 Preparation of test units

Apply a thin layer of the adhesive, to the concrete slab with a straight edge trowel. Then apply a thicker layer and comb with a notched trowel having 6 mm × 6 mm notches at 12 mm centres.

The trowel shall be held at an angle of approximately 60° to the substrate at a right angle to one edge of the slab and drawn across the slab parallel to that edge (in a straight line).

After 5 min place 10 type BI<sub>a</sub> tiles on the adhesive at a distance apart of 50 mm and load each tile (20 ± 0,05) N for 30 s.

##### 4.4.4.2 Tensile adhesion strength

After 27 days of storage under standard conditions, bond the pull-head plates to the tiles with a suitable high strength adhesive (e.g. epoxy).

After a further 24 h storage under standard conditions, determine the tensile adhesion strength of the adhesive by applying a force at a constant rate of (250 ± 50) N/s.

If fast-setting properties of adhesives are to be tested, bond the pull-head plates a minimum of 2 h before determining the tensile adhesion strength.

Report the results in newtons.

##### 4.4.4.3 Tensile adhesion strength after water immersion

Condition the test units in standard conditions for 7 days and immerse in water at the standard temperature.

After 20 days, remove the test units from the water, wipe with a cloth and bond the pull-head plates to the tiles. After a further 7 h in standard conditions, immerse the test units in water at the standard temperature.

The following day, remove the test units from water and immediately determine the tensile adhesion strength of the adhesive by applying a force at a constant rate of (250 ± 50) N/s.

Report the results in newtons.

##### 4.4.4.4 Tensile adhesion strength after heat ageing

Condition the test units in standard conditions for 14 days and then place the units in an air-circulating oven at (70 ± 3) °C for a further 14 days. Remove from the oven and bond the pull-head plates to the tiles with a suitable high strength adhesive (e.g. epoxy).

Condition the test units for a further 24 h in standard conditions and immediately determine the tensile adhesion strength of the adhesive by applying a force at a constant rate of (250 ± 50) N/s.

Report the results in newtons.

##### 4.4.4.5 Tensile adhesion strength after freeze-thaw cycle

Prepare the test units in accordance with 4.4.4.1. In addition, a layer of the adhesive approximately 1 mm thick shall be applied with a straight-edged trowel to the back face of the type tile before placing.

Condition the test units for 7 days in standard conditions and immerse in water for 21 days before carrying out 25 freeze-thaw cycles.

For each freeze-thaw cycle:

- a) remove the test units from the water and lower the temperature to  $(-15 \pm 3) ^\circ\text{C}$  within  $2 \text{ h} \pm 20 \text{ min}$ .
- b) maintain the test units at  $(-15 \pm 3) ^\circ\text{C}$  for  $2 \text{ h} \pm 20 \text{ min}$ .
- c) immerse in water at  $(20 \pm 3) ^\circ\text{C}$  and raise the temperature to  $(15 \pm 3) ^\circ\text{C}$  and maintain this temperature for a minimum of 2 h before commencing the next freeze-thaw cycle.
- d) Repeat the cycle 25 times.

After 25 cycles, bond the pull-head plates to the tiles. Allow the test units to reach standard conditions in air. Determine the tensile adhesion strength of the adhesive in less than 24 h by applying a force at a constant rate of  $(250 \pm 50) \text{ N/s}$ .

Report the results in newtons.

#### 4.4.5 Evaluation and expression of results

The individual tensile adhesion strength shall be determined to an accuracy of  $0,1 \text{ N/mm}^2$  using Equation (1):

$$S_a = \frac{F}{A} \quad (1)$$

where

$S_a$  is the individual tensile adhesion strength, in newtons per square millimetre;

$F$  is the total load, in newtons;

$A$  is the bonding area, in square millimetres ( $2\,500 \text{ mm}^2$ ).

The tensile adhesion strength for each set of conditions shall be determined as follows:

- a) determine the mean of the 10 values;
- b) discard the values falling out of the range of  $\pm 20\%$  from the mean value;
- c) if five or more than five values remain, determine the new mean value;
- d) if less than five values remain, repeat the test;
- e) determine the mode of failure of each test unit (see Figure 3).

#### 4.4.6 Test report

The information listed in 3.7.1, list items a) to i), shall be provided plus 3.7.2 list item d): adhesion strength for each condition, in newtons per square millimetre.



## 4.5 Determination of transverse deformation

### 4.5.1 General

Transverse deformation shall be tested following the general test conditions and procedures given in Clause 3 and the following specific instructions.

### 4.5.2 Test materials and apparatus

**4.5.2.1 Substrate**, of polyethylene film, of minimum thickness 0,15 mm.

**4.5.2.2 Plastic container**, capable of being sealed to make it airtight, with an internal volume of  $(26 \pm 5)$  l, e.g. a container with dimensions of  $(600 \pm 20)$  mm  $\times$   $(400 \pm 10)$  mm  $\times$   $(110 \pm 10)$  mm.

**4.5.2.3 Support**, rigid, smooth and flat, for the polyethylene film.

**4.5.2.4 Anvil**, of metallic construction, conforming to the dimensions of Figure 11.

**4.5.2.5 Test jig**, of two metallic cylindrical supports, of diameter  $(10 \pm 0,1)$  mm, spaced  $(200 \pm 1)$  mm centre to centre, of length 60 mm minimum (see Figure 12).

**4.5.2.6 Template A**, smooth, rigid, non-absorbent rectangular frame of internal dimensions  $(280 \pm 1)$  mm  $\times$   $(45 \pm 1)$  mm and thickness  $(5 \pm 0,1)$  mm, e.g. made of polytetrafluoroethylene (PTFE) or metal.

A round hole of 2 mm diameter drilled at each internal corner is recommended to ease production of the test piece (see Figure 13).

**4.5.2.7 Template B**, smooth, rigid, non-absorbent mould (see Figure 14) or similar device capable of producing a test specimen of dimensions  $(300 \pm 1)$  mm  $\times$   $(45 \pm 1)$  mm  $\times$   $(3 \pm 0,05)$  mm.

**4.5.2.8 Test machine**, which is a press, capable of applying the anvil (4.5.2.4) to the test piece at a rate of 2 mm/min.

**4.5.2.9 Flow table**, capable of being used for the compaction of the 280 mm  $\times$  45 mm  $\times$  5 mm specimen, and complying with Figure 15.

### 4.5.3 Procedure

#### 4.5.3.1 Preparation of substrate

Fix the polyethylene film (4.5.2.1) firmly to the rigid support (4.5.2.3), ensuring the surface, to which the adhesive is to be applied, is not distorted, e.g. without pleats or wrinkles.

#### 4.5.3.2 Preparation of test units

Hold the template A firmly onto the polyethylene film.

Trowel sufficient adhesive across the template and then screed clean such as to neatly and completely fill the hole in the template.

Clamp the mould firmly to the flow table and compact the sample using 70 jolts.

Lift the mould gently from the flow table and carefully remove the template vertically.

Apply a layer of release agent to the template B and position it centrally over the specimen. Load the template with a mass capable of exerting a force of  $(100 \pm 0,1)$  N and an approximate cross-sectional area of  $(290 \times 45)$  mm. The applied pressure ensures that the material fully fills the recess of the template to the

required thickness. Remove any excess material from the sides of the template and 1 h later, remove the mass.

After 48 h, remove the template B.

Prepare 6 samples for each test.

#### 4.5.3.3 Conditioning

Immediately after the removal of template B, place 6 specimens, on the support, horizontally into the plastic container and seal it to make it air tight.

Condition the test units at  $(23 \pm 2)$  °C. After 12 days, remove them from the plastic container and condition them for 14 days in air in standard conditions.

#### 4.5.3.4 Transverse deformation

After conditioning has been completed, remove the specimens from the polyethylene film and measure their thickness, using a calliper with 0,01 mm precision, at three positions, i.e. in the middle and  $(50 \pm 1)$  mm from each end. If the three values fall within the required tolerance of  $(3,0 \pm 0,1)$  mm, calculate the average value; discard any specimen which falls outside the required permissible thickness. Place the test sample on the test jig (see Figure 12).

The starting point is defined when the anvil touches the sample. Deform the sample, from the starting point, with a transverse load applied by the anvil at a rate of 2 mm/min until failure.

Record the deformation from the starting point, in millimetres.

Repeat the test on the other test pieces. A minimum of 3 test specimens is required.

#### 4.5.4 Evaluation and expression of results

The transverse deformation is determined to 0,1 mm, by calculating the average value of the deformations obtained in the test. The classes are designated in ISO 13007-1:2010, Table 3.

#### 4.5.5 Test report

The information listed in 3.7.1, list items a) to i), shall be provided plus 3.7.2 list item e): deformation, individual and mean values, in millimetres.

### 4.6 Determination of chemical resistance

#### 4.6.1 General

Reaction resin (R) adhesives and grouts (RG). Chemical resistance shall be determined following the general test conditions and procedures given in Clause 3 and the following specific instructions.

#### 4.6.2 Apparatus

**4.6.2.1 Mould**, right cylinder, with dimensions of  $(25 \pm 1)$  mm in diameter by  $(25 \pm 1)$  mm high. The moulds may be constructed in any manner that allows the formation of the desired test specimen.

Typical moulds consist of a  $(25 \pm 1)$  mm thick flat plastic board, in which  $(25 \pm 1)$  mm diameter holes have been cut, and to the bottom of which a flat and smooth plastic sheet, at least 6 mm thick, without holes, is attached by means of screws or any other suitable system. Alternatively, the mould may consist of sections of round plastic tubing or pipe,  $(25 \pm 1)$  mm inside diameter, and  $(25 \pm 1)$  mm long, having sufficient wall

thickness to be rigid and retain dimensional stability during the moulding operation, and a 6 mm thick flat plastic sheet on which one open end of each section can be rested.

The material from which the mould is constructed shall be chemically inert and shall have anti-stick properties. Polyethylene, polypropylene, polytetrafluorethylene and metal forms having a sintered coating of tetrafluoroethylene polymer have been found to be satisfactory.

#### 4.6.2.2 Containers

**4.6.2.2.1 Wide mouth jars**, of sufficient capacity, fitted with plastic or plastic-lined metal screw caps for low temperature tests involving media of low volatility.

**4.6.2.2.2 Erlenmeyer flasks**, of sufficient capacity, fitted with standard-taper-joints and a reflux condenser attachment for use with volatile media.

**4.6.2.2.3 Container**, as described in 4.6.2.2.1 and 4.6.2.2.2 of a suitable inert material for use with media which attack glass.

**4.6.2.3 Compression machine**, consisting of a test machine with suitable capacity and sensitivity for the test and with a variable testing speed. The machine shall be capable of applying the compression load to the specimen through a suitable compression jig designed to provide self-alignment with specimen.

**4.6.2.4 Chemical agents**, consisting of the media to which the materials are to be exposed in service.

#### 4.6.3 Test specimens

##### 4.6.3.1 Number

The number of specimens required is dependent upon the number of test media to be employed, the number of different temperatures at which testing is performed and the frequency of test intervals. In any case, the test specimen shall consist of sets of a minimum of three cylinders for one medium, at a single temperature and for each test interval. In addition, one set of at least three specimens shall be available for test immediately following the conditioning period, and other sets of at least three, equivalent to the number of test temperatures, for the total test period. Calculate the total number of specimens required using Equation (2):

$$N = n (M \times T \times I) \pm (n \times T) \pm n \quad (2)$$

where

$N$  is the number of specimens;

$n$  is the number of specimens for a single test;

$M$  is the number of media;

$T$  is the number of test temperatures;

$I$  is the number of test intervals.

##### 4.6.3.2 Dimensions

The test units shall be cast right cylinders,  $(25 \pm 1)$  mm in diameter by  $(25 \pm 1)$  mm high, with flat smooth faces normal to the axis of the cylinder, prepared in moulds described in 4.6.2.1, and employing no release agent in the mould.

#### 4.6.3.3 Preparation

Mix the components in the ratio specified by the manufacturer's instructions. Blend the parts using a suitable hand tool or machine mixer, making sure any ingredients are thoroughly and uniformly mixed.

#### 4.6.3.4 Conditioning

Condition the test units for 7 days in standard conditions (see 3.2), the 7 days include the curing time in the mould. After the 7 days, proceed as described in 4.6.5 on one set of specimens.

#### 4.6.4 Procedure

Immediately following the conditioning period, measure the diameter of all test specimens to the nearest 0,03 mm using a micrometer. Make two measurements at right angles to each other and record the diameter as the average of the two.

Following the diameter measurement, weigh all the specimens to the nearest 0,001 g on an analytical balance and record the values. Prior to immersion, record a brief description of the colour and surface appearance of the specimen and of colour and transparency of the test medium.

Place the weighed specimens, to be immersed, on their curved sides in the individual containers.

**4.6.4.1** Add sufficient chemical agent to continuously cover each specimen by a minimum 10 mm. Place the closed container in a constant-temperature oven adjusted to the required temperature or in a suitable adjusted liquid bath simulating the real service and exposure as closely as possible. Replace agents that are known to be unstable, as often as necessary, in order to maintain the original chemical composition and concentration, for the planned intervals.

**4.6.4.2** Remove the specimen after 28 days of immersion to determine the chemical attack. Other exposure periods may be employed.

Clean each specimen by three quick rinses in running cold tap water and quick dry by blotting with a paper towel between each rinse. After the final blotting allow the specimen to dry for 30 min, resting on its curved surface, and weigh to the nearest 0,001 g and measure the diameter of the test specimen as described in 4.6.5. Note any indication of surface attack on the specimen, any discoloration of the test specimen and the formation of any sediment in the chemical agent.

#### 4.6.5 Determination of the compressive strength for one set of specimens

Determine the compressive strength for one set of specimens

- a) immediately after the conditioning period,
- b) after the exposure period for each chemical agent and each temperature, and
- c) after ageing in air for the total test period at each test temperature.

The elapsed time between the removal of each specimen from the test medium and the compressive test should be uniform for all specimens. Place each specimen in the testing machine such that the plane faces of the cylinder are in contact with the surface of the compression tool or cage. Apply the load to the specimen at a cross-head movement of  $(5,5 \pm 0,5)$  mm/min when the machine is running without load. Break the specimen and record the maximum load.

**4.6.6 Evaluation and expression of results**

**4.6.6.1 Mass change**

Calculate to the nearest 0,01 % the percentage loss or gain in mass of the specimen during exposure for each examination period, taking the conditioned mass after conditioning as 100 % as follows:

Change in mass is given by Equation (3):

$$\Delta m = \left[ \frac{(m_2 - m_1)}{m_1} \right] \times 100 \tag{3}$$

where

$\Delta m$  is the mass fraction change, in per cent;

$m_1$  is the mass of the specimen after initial conditioning, in grams;

$m_2$  is the mass of the specimen after immersion, in grams.

Determine the mean of the three values or more. A result showing a plus (+) sign shall indicate a gain in mass and a minus (-) sign shall indicate a loss in mass.

**4.6.6.2 Diameter change**

Calculate to the nearest 0,01 % the percentage change of the diameter of the specimen during exposure for each examination period, taking the diameter after the 7 days conditioning as 100 %.

Change in diameter is given by Equation (4):

$$\Delta D = \left[ \frac{(D_2 - D_1)}{D_1} \right] \times 100 \tag{4}$$

where

$\Delta D$  is the diameter change, in per cent;

$D_1$  is the diameter of the specimen after the initial conditioning, in millimetres;

$D_2$  is the diameter of the specimen after the exposure period, in millimetres.

Determine the mean of the three values or more. A result showing a plus (+) sign shall indicate a gain in diameter and a minus (-) sign shall indicate a loss in diameter.

**4.6.6.3 Change of compressive strength.**

Calculate to the nearest 0,01 % the percentage decrease or increase of compressive strength of the specimen during exposure for each examination period, taking the compressive strength after the 7 days conditioning period in standard conditions as 100 %. Calculate the cross-sectional area of the specimen on the diameter value as determined in 4.6.4.

Change in compressive strength is given by Equation (5):

$$\Delta C = \left[ \frac{(C_2 - C_1)}{C_1} \right] \times 100 \tag{5}$$

where

$\Delta C$  is the compressive strength change, in per cent;

$C_1$  is the load per cross-sectional area of specimen after conditioning period, in newtons per square millimetre;

$C_2$  is the load per cross-sectional area of specimen after exposure period, in newtons per square millimetre;

A result showing a plus (+) sign shall indicate a gain in compressive strength and a minus (–) sign shall indicate a loss in compressive strength.

#### 4.6.7 Test reports

The information listed in 3.7.1, list items a) to i), shall be provided plus the following:

- 3.7.3, list item a): test conditions of exposure to each chemical agent, frequency of change of chemical agent, concentration, temperature, etc.;
- 3.7.3, list item b): colour and surface appearance of test units before and after testing;
- 3.7.3, list item c): total duration of the test and the exposure periods, in days.

For each exposure period, the following data are required:

- a) average percentage of mass change of specimen;
- b) average percentage of diameter change;
- c) appearance of specimen after immersion (surface cracks, loss of gloss, etching, pitting, softening, etc.);
- d) appearance of the test chemical agent (discolouration, sediment, etc.);
- e) average percent change in the compressive strength of specimen.

Dimensions in millimetres

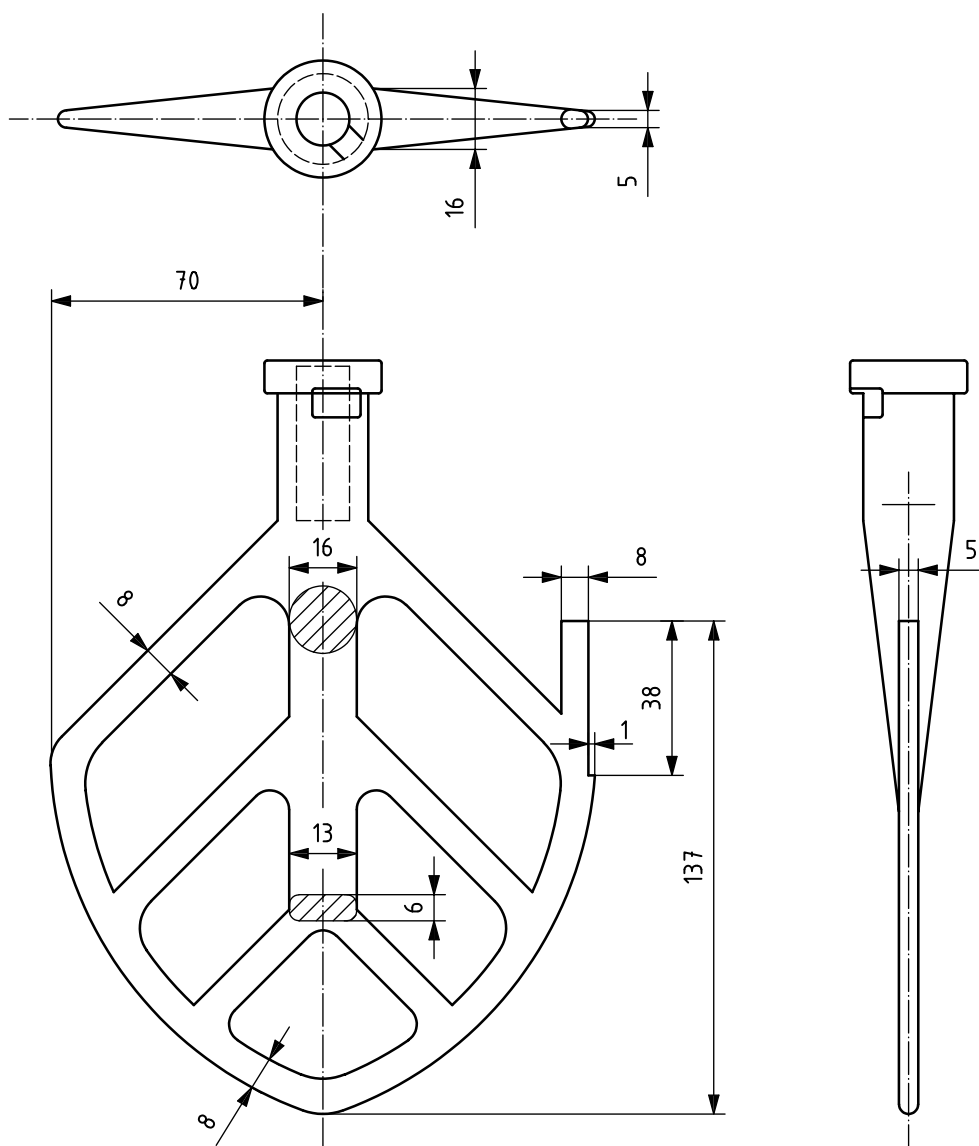
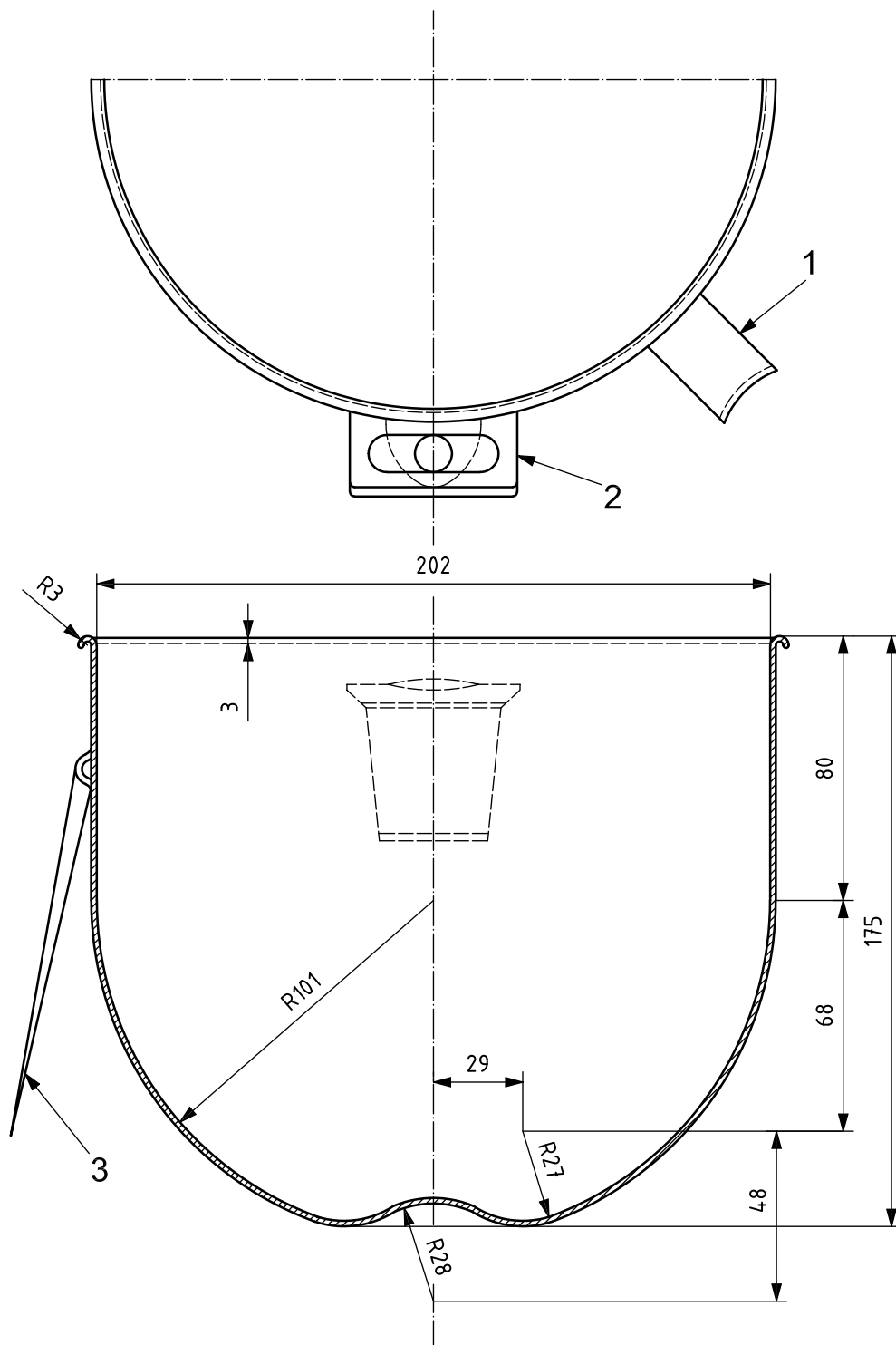

Figure 1 — Paddle

Dimensions in millimetres



**Key**

- 1 front handle
- 2 side handle
- 3 back bowl pin assembly

**Figure 2 — Mixing bowl**



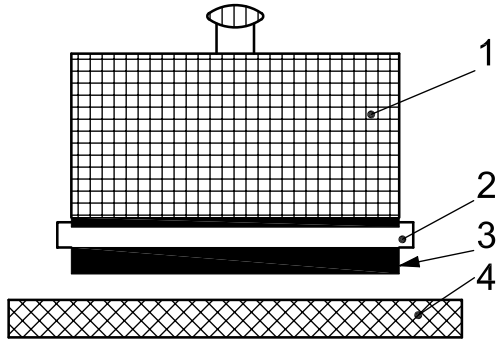

a) Adhesive failure between adhesive and substrate — AF-S

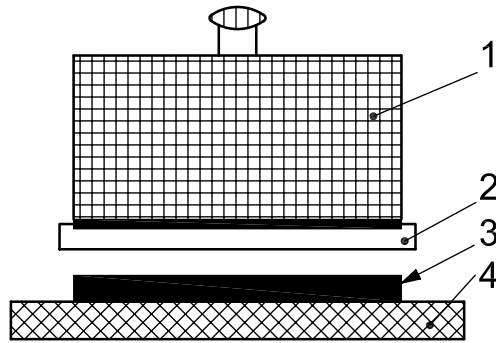

b) Adhesive failure between tile and adhesive — AF-T

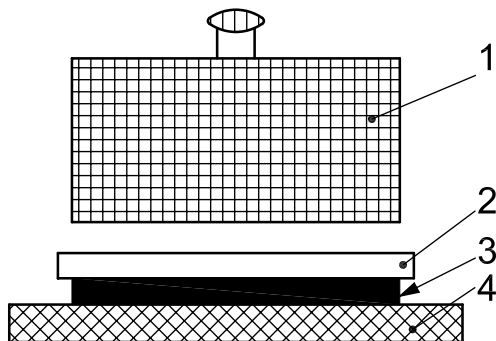

c) Adhesive failure between tile and pull-head plate — BF

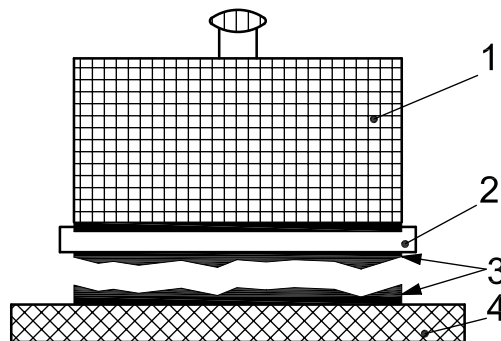

d) Cohesive failure within the adhesive — CF-A

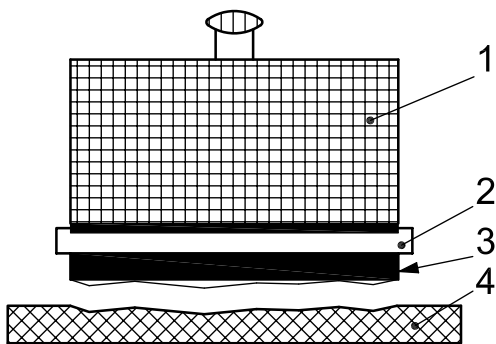

e) Cohesive failure within the substrate — CF-S

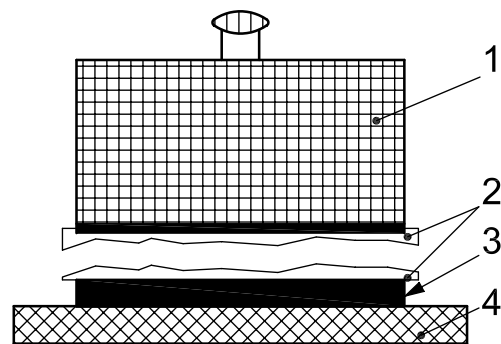

f) Cohesive failure within the tile — CF-T

**Key**

- 1 pull-head plate
- 2 tile
- 3 adhesive
- 4 substrate (concrete slab)

**Figure 3 — Failure pattern**

Dimensions in millimetres

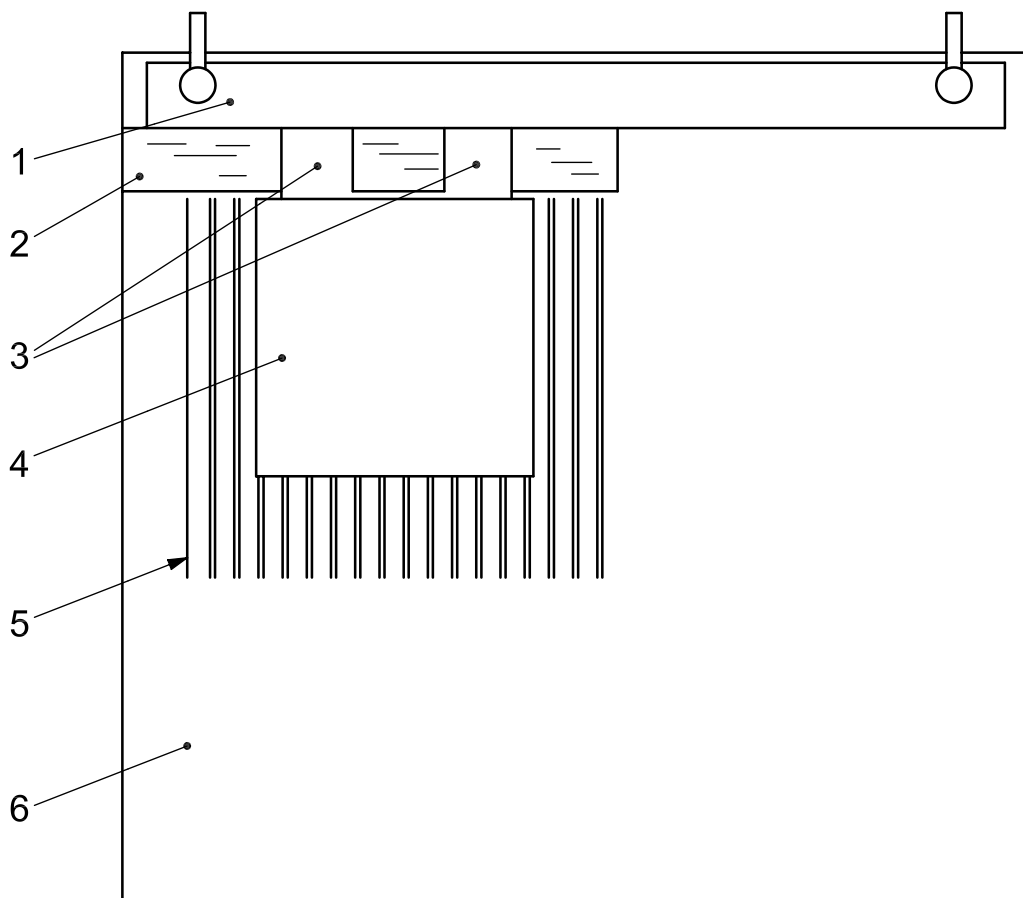
**Key**

- 1 steel straight edge
- 2 masking tape, 25 mm wide
- 3 (25 × 25 × 10) mm thick spacer of spacing bars
- 4 tile (100 × 100) mm
- 5 adhesive
- 6 concrete substrate

**Figure 4 — Slip apparatus**

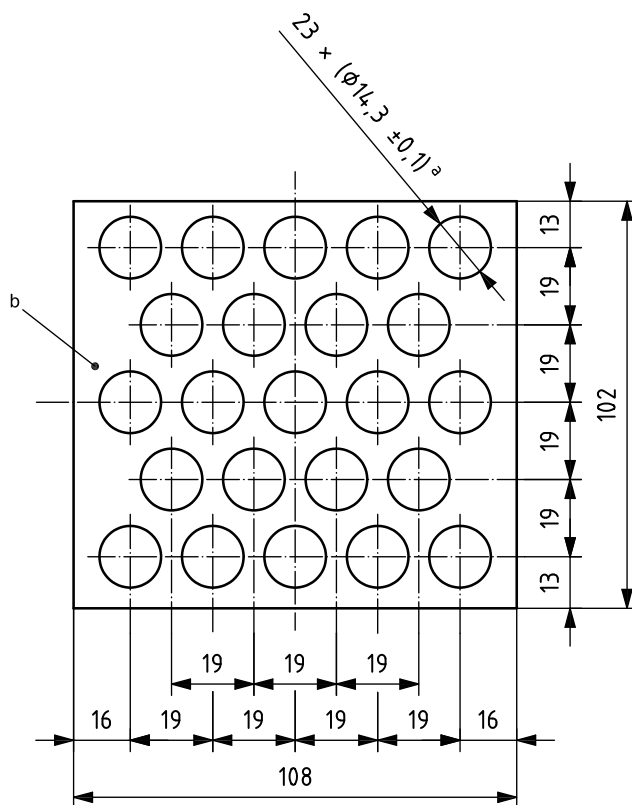

The material is PTFE or similar, with non-stick properties.

The actual coverage is  $(50 \pm 5)$  %.

<sup>a</sup> Hole.

<sup>b</sup> Thickness of template is  $1,5 \text{ mm} \pm 0,1 \text{ mm}$ .

**Figure 5 — Template for testing dispersion (D) adhesives**

Dimensions in millimetres

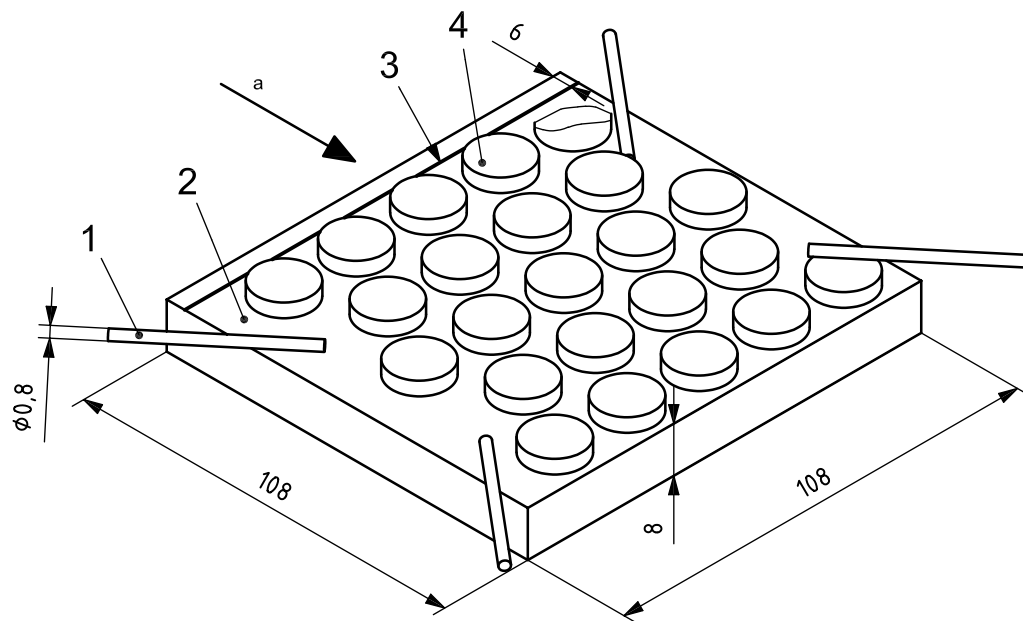
**Key**

- 1 spacer rod (0,8 mm in diameter and 40 mm long), positioned as indicated
- 2 ceramic test tile (108 mm × 108 mm)
- 3 pencil guide line
- 4 adhesive
- a Direction of applied load.

**Figure 6 — Preparation of tile test unit — D**

Dimensions in millimetres

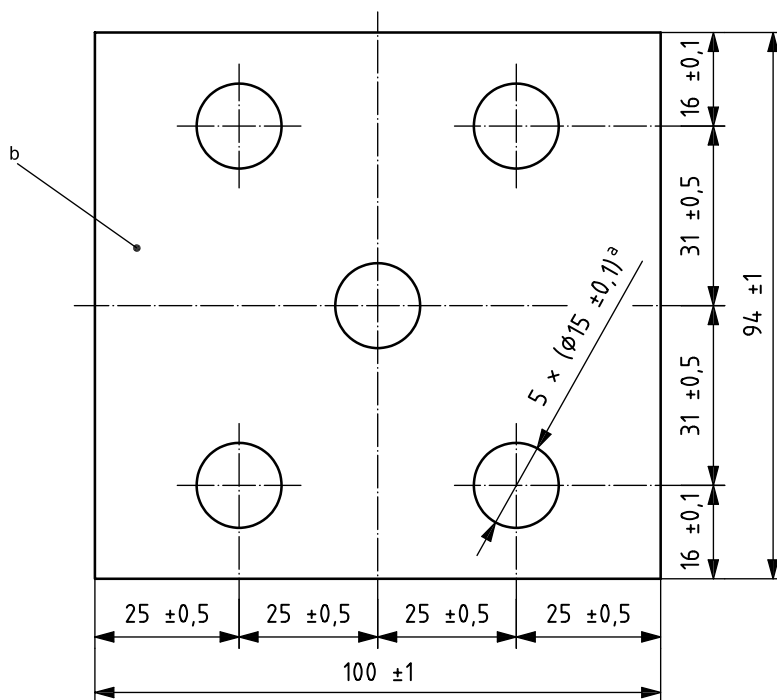

The material is PTFE or similar, with non-stick properties.  
 The actual coverage is 1 660 mm<sup>2</sup>.

- a Hole.
- b Thickness of template.

**Figure 7 — Template for testing reaction resin (R) adhesive**

Dimensions in millimetres

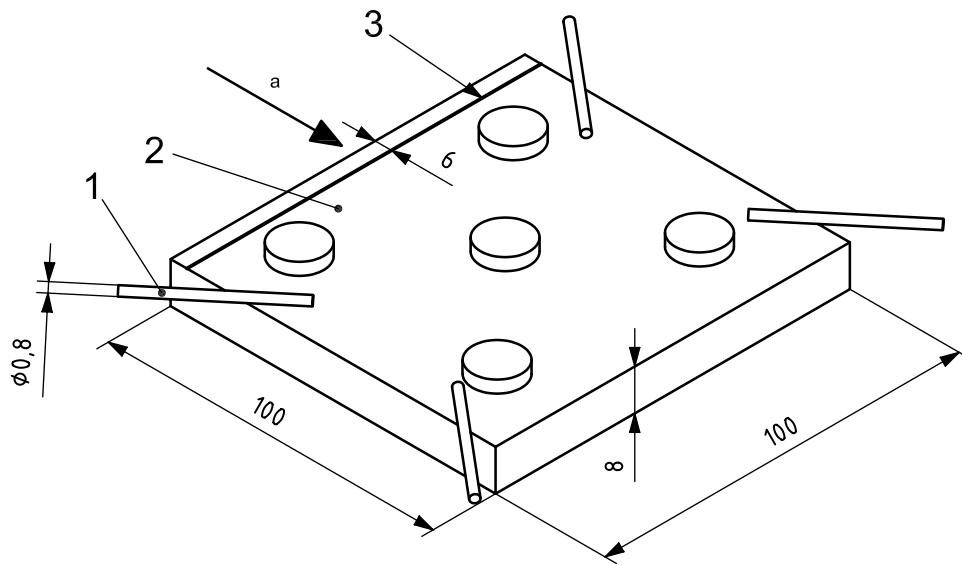

**Key**

- 1 spacer rod
- 2 ceramic test tile
- 3 pencil guide line
- <sup>a</sup> Direction of force or load.

**Figure 8 — Preparation of tile test unit — R**

Dimensions in millimetres

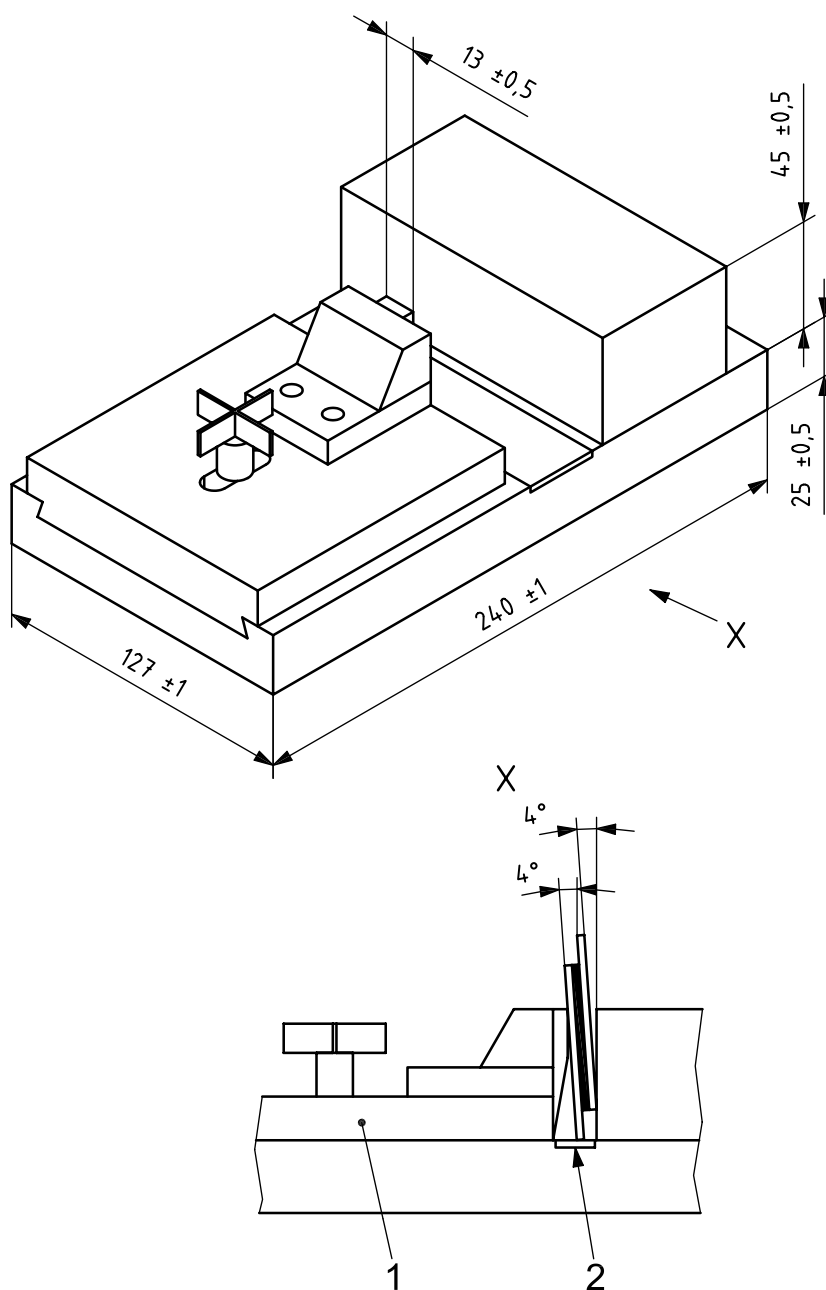

**Key**

- 1 adjustable jaws (from 12 mm to 45 mm)
- 2 hardened insert

**Figure 9 — Jig for shear adhesion test using a vertical compression machine**

Dimensions in millimetres

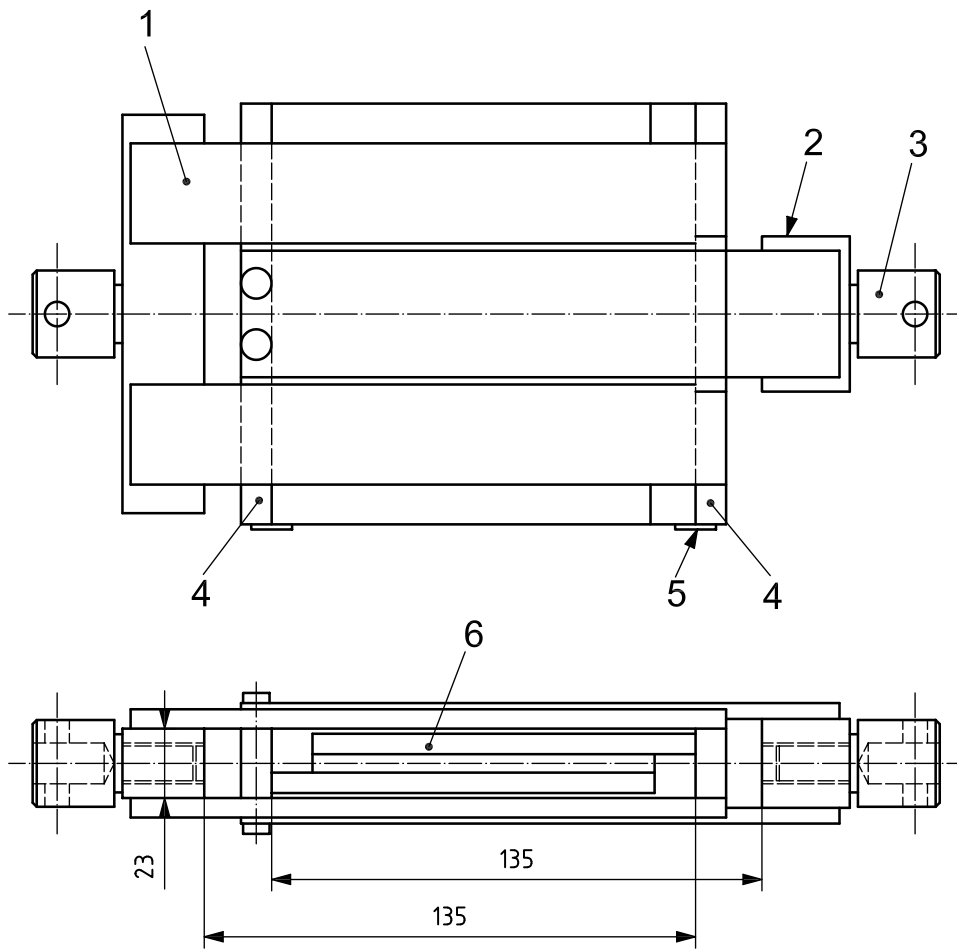

**Key**

- 1 box section frame
- 2 "U" section frame
- 3 adapter
- 4 pressure plate
- 5 stop
- 6 test unit

**Figure 10 — Jig for shear adhesion test using a tensile machine**



Dimensions in millimetres

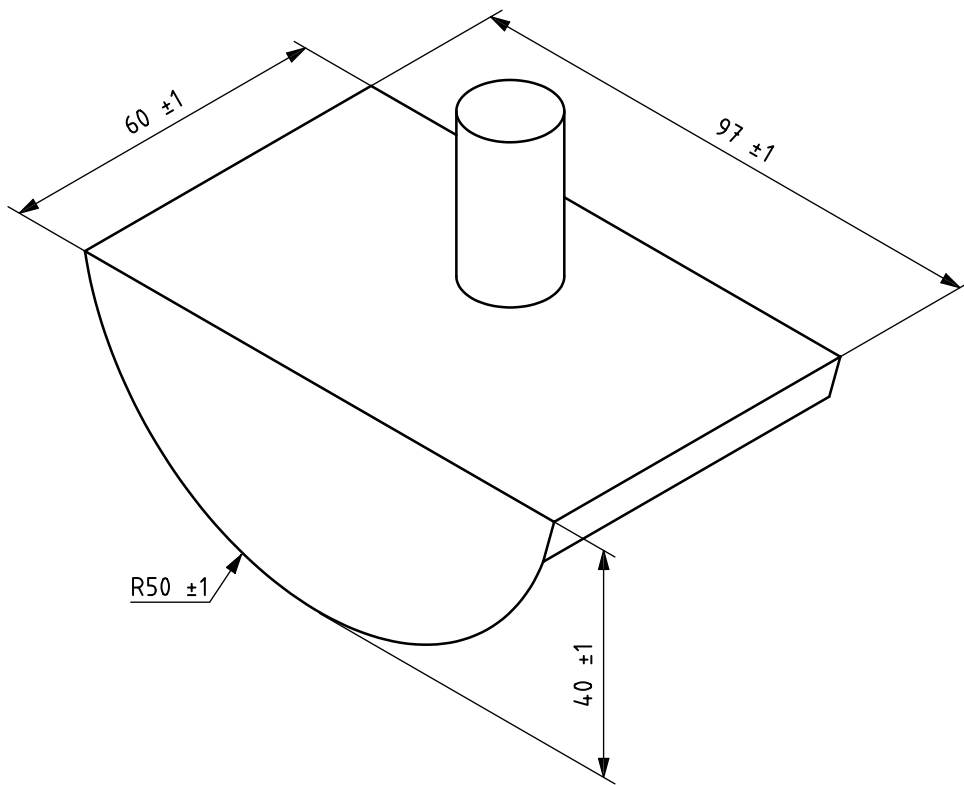
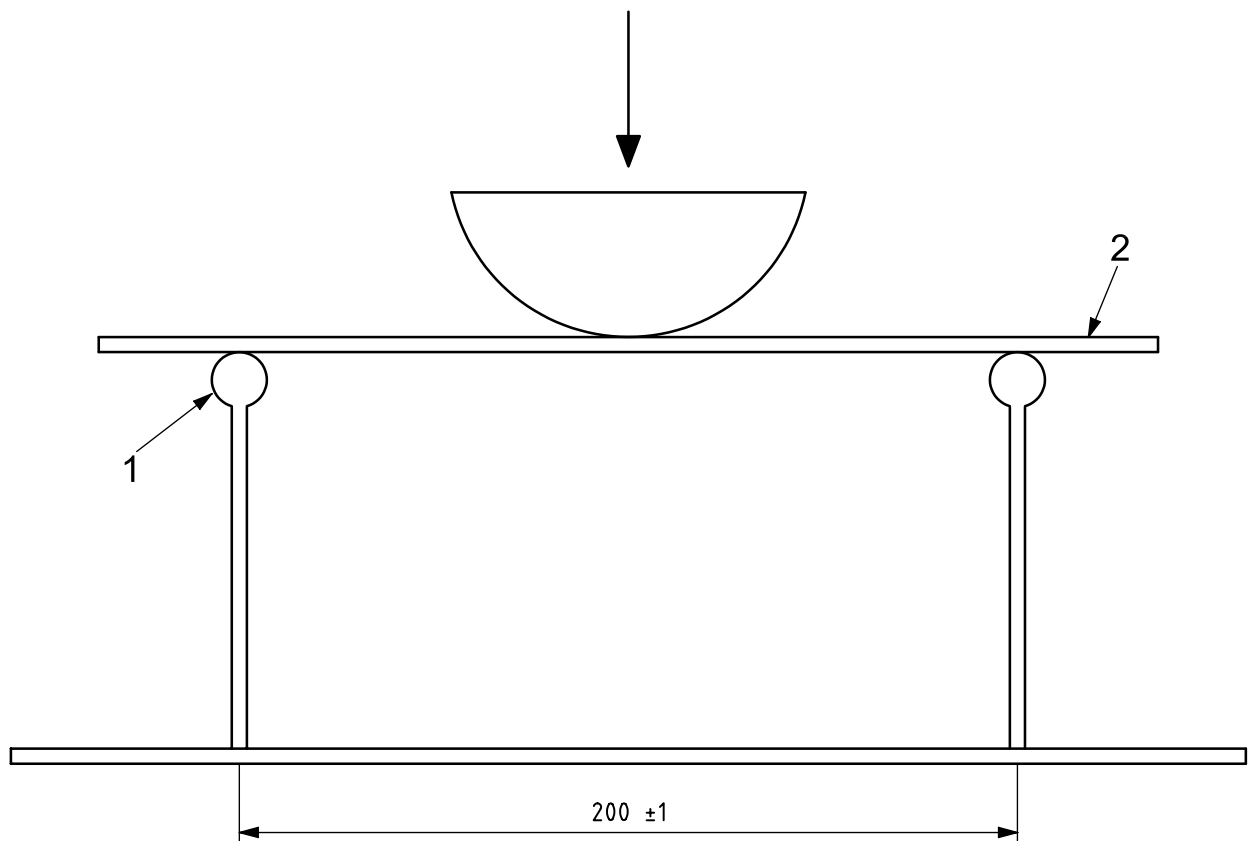

Figure 11 — Anvil

Dimensions in millimetres



**Key**

- 1 cylindrical support, diameter  $(10 \pm 0,1)$  mm, length 60 mm minimum
- 2 adhesive  $(3 \pm 0,1)$  mm thick

**Figure 12 — Test jig**

Dimensions in millimetres

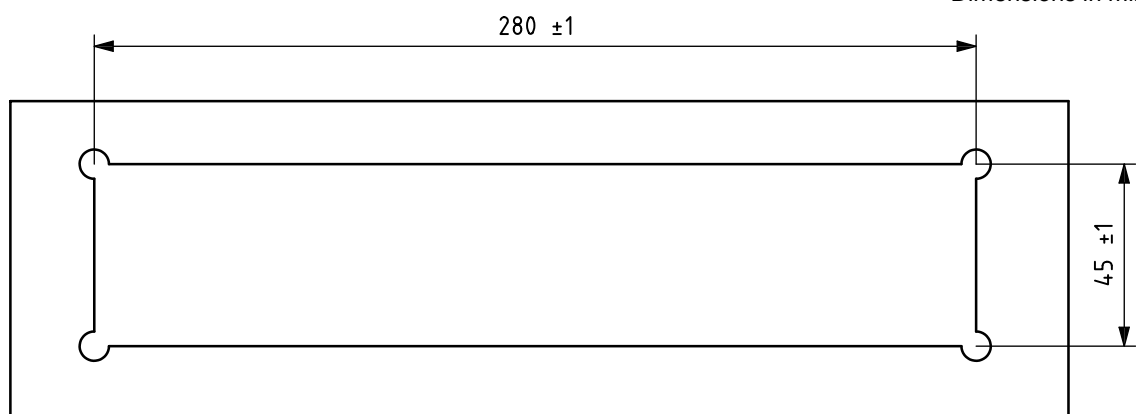

**Figure 13 — Template A**

Dimensions in millimetres

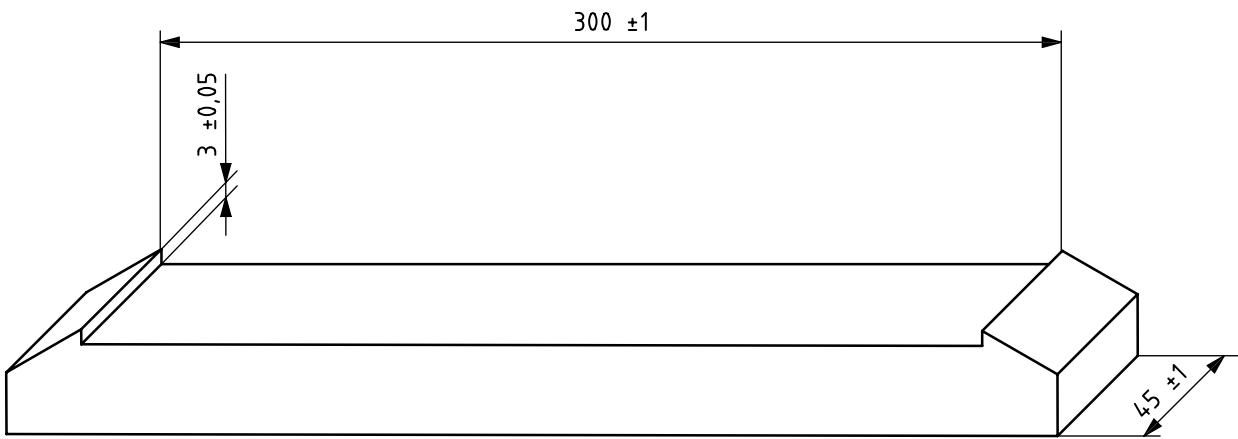

Figure 14 — Template B

Dimensions in millimetres

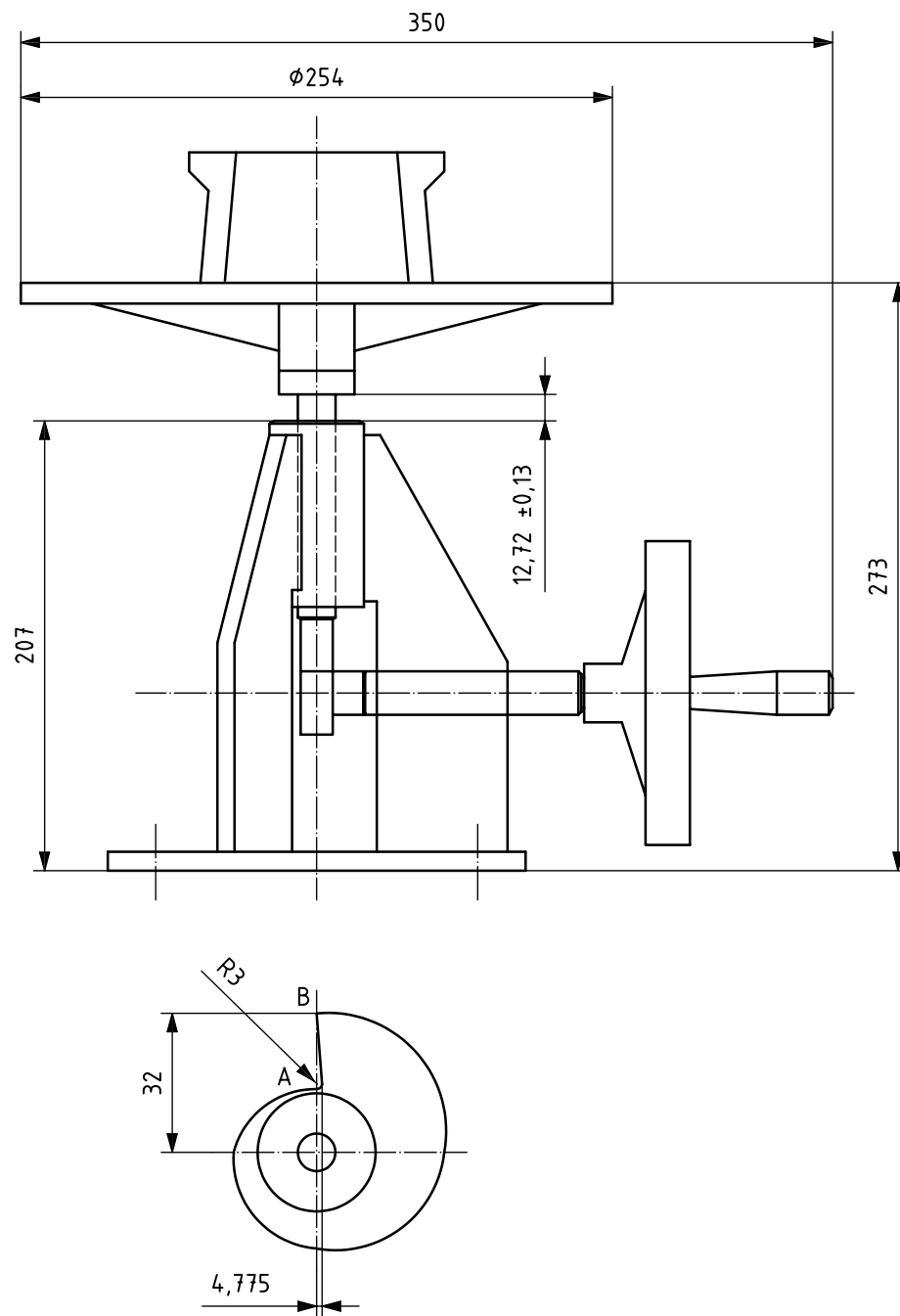

Figure 15 — Flow table

## Annex A (informative)

### Concrete test slab

#### A.1 General information

A concrete test slab suitable for the adhesive tests described in this part of ISO 13007 may be manufactured and tested using the procedures described in this annex. Other concrete products meeting the requirements listed in 3.5 may be utilized.

#### A.2 Test conditions

A.2.1 Test conditions given in 3.2 are appropriate.

#### A.3 Apparatus

A.3.1 **Pull-head plates**, consisting of square metallic (e.g. steel, aluminum) plates, with dimensions of  $(50 \pm 1)$  mm  $\times$   $(50 \pm 1)$  mm and a minimum thickness of 10 mm with a suitable fitting for connection to the tensile testing machine.

A.3.2 **Tensile testing machine**, capable of applying the load to the pull-head plate at the rate of  $(250 \pm 50)$  N/s, through a suitable fitting that does not exert any bending force.

A.3.3 **Carsten-Röhrchen flask**, or other suitable apparatus, capable of measuring the water absorption at the surface of the concrete slab (see Figure A.1).

#### A.4 Concrete test slab

##### A.4.1 Manufacture of the concrete slab

The specification (listed in 3.5) may be achieved by using the following procedure to manufacture the concrete slab:

- binder: Portland cement;
- aggregate: gravel sand, of 0 mm to 8 mm particle size, continuous grading curve between A and B (see Figure A.2);
- mix ratio binder and aggregate: 1:5 in proportion mass fraction;
- ultrafines content per cubic metre of:  $500 \text{ kg/m}^3$  prepared concrete;
- ready mixed concrete: the concrete shall contain ultra fines in order to be properly workable and have a closed structure; the ultra fines content consists of cement and aggregate particle size up to 0,125 mm;
- water: cement ratio: 0,5;

- manufacture: vertically or horizontally in moulds, avoid the use of any mould release agent;
- compaction: 90 s on a vibrating table at 50 Hz;
- conditioning: the slabs shall be stored for 24 h under standard conditions followed by six days water immersion at  $(20 \pm 2)$  °C. Before use or before being tested for water absorption and surface cohesive strength, the concrete slabs shall be stored separately, in vertical position, in a dry and ventilated environment, for at least 3 months and conditioned for at least 24 h under standard conditions.

The test surface shall have a finish similar to that obtained by using a wooden float and be clean and dust-free at the time of the test.

#### **A.4.2 Measurement of surface water absorption**

Water absorption at the surface of the concrete slab shall be determined by the following method.

- a) Bond a graduated measuring tube (Carsten Röhrchen flask) to the concrete slab by means of a suitable sealant.
- b) After the sealant has cured, fill the measuring tube with water, to the upper level.
- c) Record the water level every 60 min during the 4 h of the test, and draw the absorption as a function of time.
- d) Perform at least three tests on a reference concrete slab from each batch.

#### **A.4.3 Measurement of surface cohesive strength**

The tensile strength between pull-head and concrete surface shall be at least  $1,5 \text{ N/mm}^2$ . The strength shall be determined by bonding at least five pull-head plates directly to the slab, e.g. with an epoxide resin, and determining the tensile adhesion strength by applying a force which increases at a constant rate of  $(250 \pm 50) \text{ N/s}$ .

#### **A.4.4 Recording of data**

The following items shall be recorded:

- a) description of the concrete slab and reference to the batch;
- b) handling and storage of concrete slabs before testing;
- c) water absorption of concrete slab, representative of the batch;
- d) moisture content of the concrete slabs, representative of the batch;
- e) tensile adhesion strength of concrete slab, representative of the batch;
- f) any other factor that might have influenced the result;
- g) date of the test.

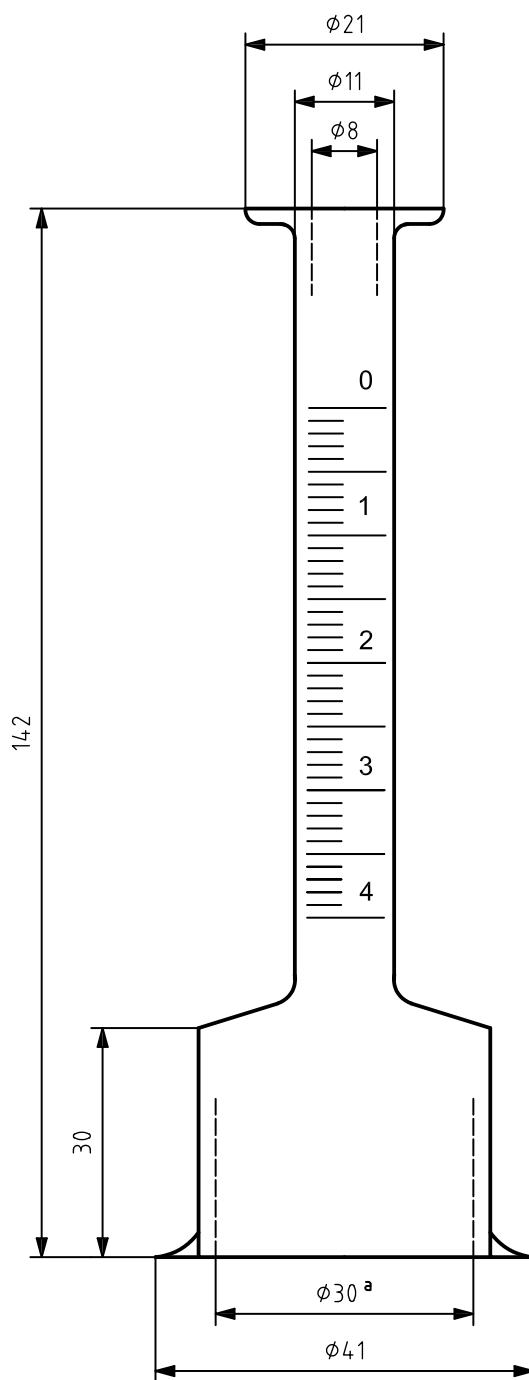

<sup>a</sup> Area = 707 mm<sup>2</sup>.

**Figure A.1 — Apparatus for evaluating water absorption (Carsten-Röhrchen flask)**

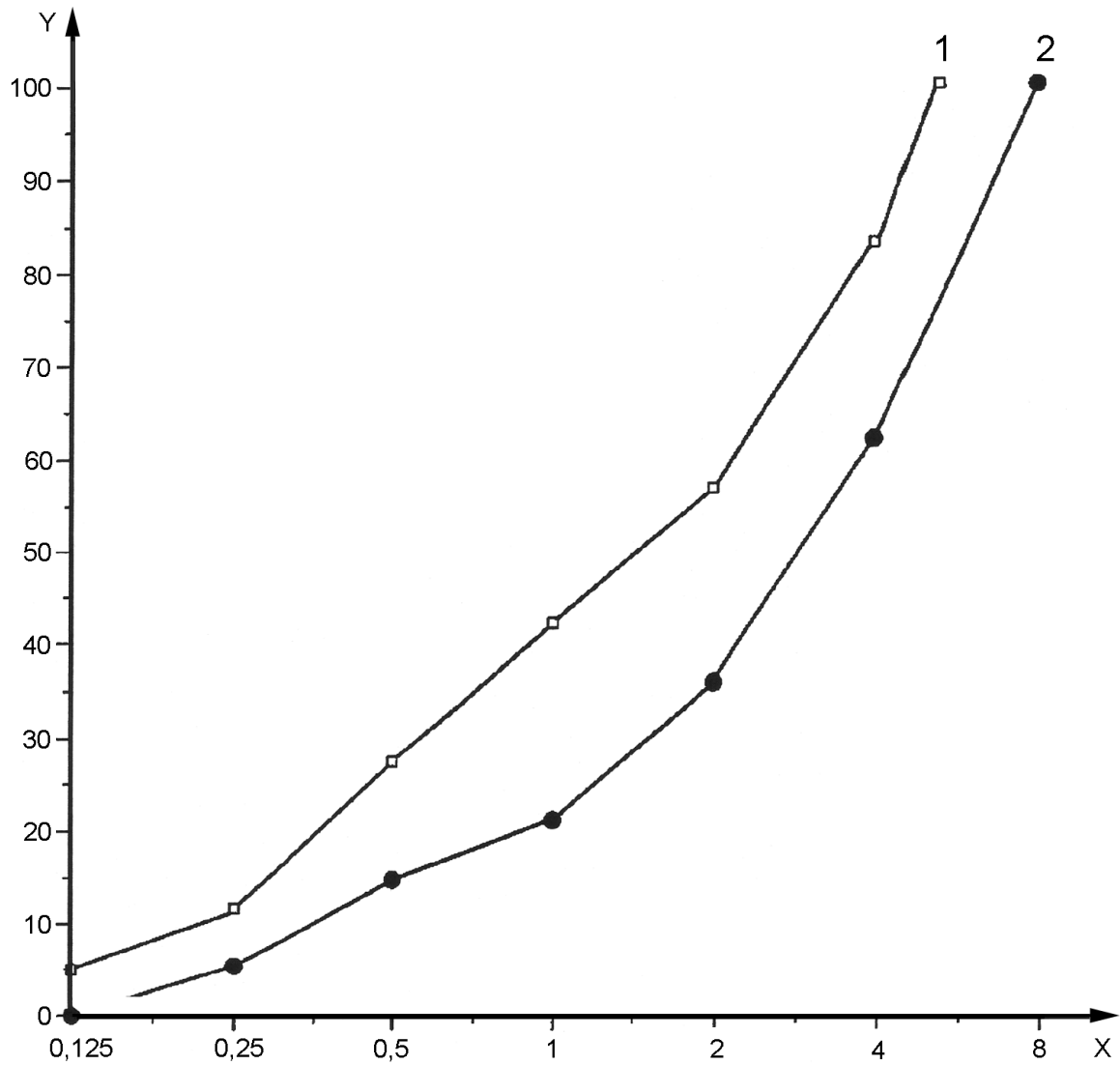
**Key**

X nominal aperture size, in millimetres

Y undersize, as percentage by mass

1 curve A

2 curve B

**Figure A.2 — Grading curves for 8 mm maximum particle size**



